



Guardian[®] FABXR Checkmate Bracket

➤ Assembly & Operation Guide

Contents

| | |
|----------------------------------|----|
| Porta Gantry Rapide 1100 | 4 |
| Porta Gantry Rapide 2200 | 6 |
| Porta Gantry; S & M | 8 |
| Porta Gantry | 12 |
| T Davit | 14 |
| Porta Davit Quantum | 16 |
| Porta Davit Quantum Single Winch | 20 |
| Porta Davit Quantum Double Winch | 22 |
| Fitting device into the Bracket | 24 |



Lightweight. Portable. **Safe.**

Please read the following instructions and guidance notes carefully. These have been designed to aid users in carrying out the correct assembly of the bracket for each of our compatible lifting systems. Systems compatible with this product are:

- **PORTA**GANTRY^[R&IDE]
- **PORTA**GANTRY
- **T**DAVIT
- **PORTA**DAVIT^[QUANTUM]

➤ Assembly Instructions: PORTAGANTRY RAPIDE® 1100

The following instructions detail the assembly of the FABXR/Checkmate Bracket [US-RAWB001020] for the PORTAGANTRY RAPIDE, both Small and Medium frame types.

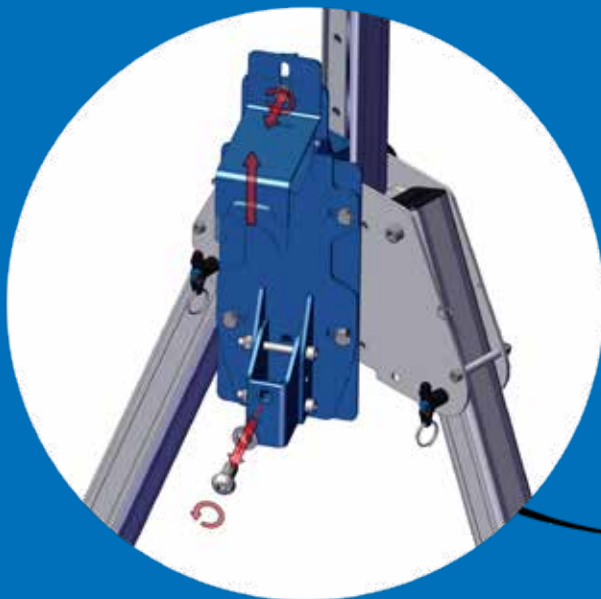

Appropriate PPE should be worn: ➤ Gloves ➤ Protective Footwear

Assembling the PORTAGANTRY RAPIDE 1100: FABXR/Checkmate Bracket



- The bracket comes with the bolts supplied, as shown above.

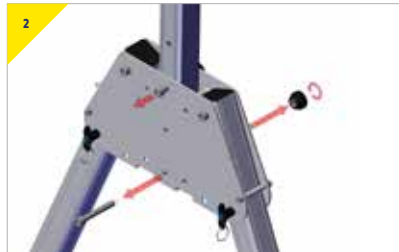

- Remove the bottom bolt and loosen the top bolt.



- Offer up bracket using keyhole slot, hook and push bracket down and tighten the bolt.



- Insert and secure tommy screw in bottom hole.



- Prepare the bracket to receive the device and remove the bolt from the bottom connector and loosen the top connector.

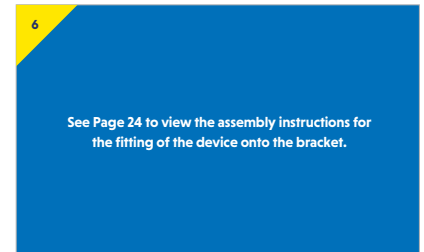

See Page 24 to view the assembly instructions for the fitting of the device onto the bracket.

➤ Assembly Instructions: PORTAGANTRY RAPIDE® 2200

The following instructions detail the assembly of the FABXR/Checkmate Bracket [US-RAWB001020] for the PORTAGANTRY RAPIDE, both Small and Medium frame types.

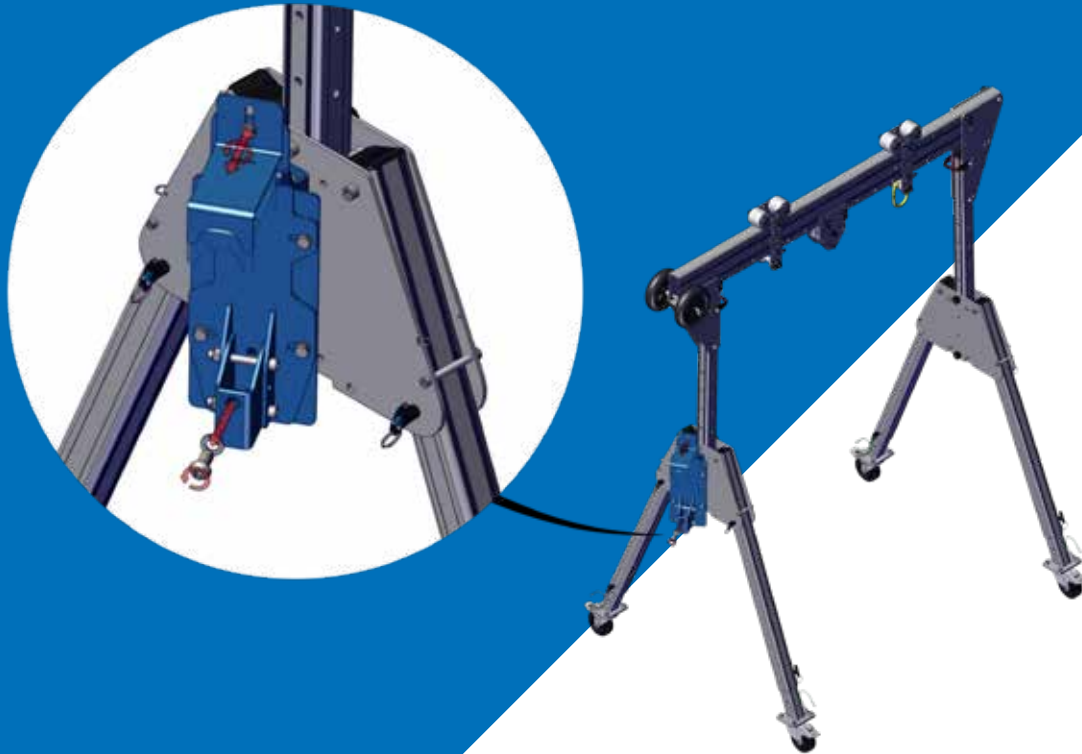

Appropriate PPE should be worn: ➤ Gloves ➤ Protective Footwear

Assembling the PORTAGANTRY RAPIDE 2200: FABXR/Checkmate Bracket



- The bracket comes with the bolts supplied, as shown above.



- Loosen the top bolt without removing.

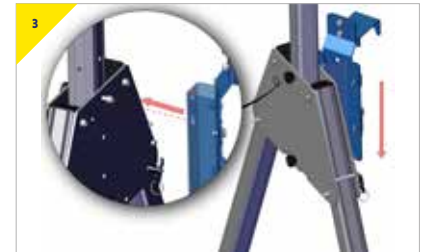

- Offer up bracket using keyhole slot, hook and push bracket down into place and tighten the bolt to secure.



- Insert and secure tommy screw in bottom hole.



- Prepare the bracket to receive the device and remove the bolt from the bottom connector and loosen the top connector.

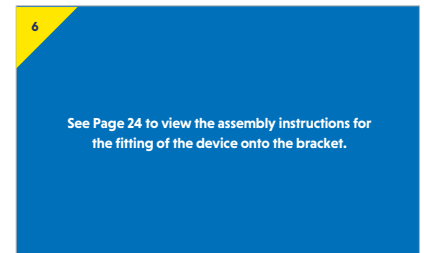

See Page 24 to view the assembly instructions for the fitting of the device onto the bracket.

➤ Assembly Instructions: PORTAGANTRY®; S & M

The following instructions detail the assembly of the FABXR/Checkmate Bracket [US-RAWB001020] for the PORTAGANTRY, both Small and Medium frame types.

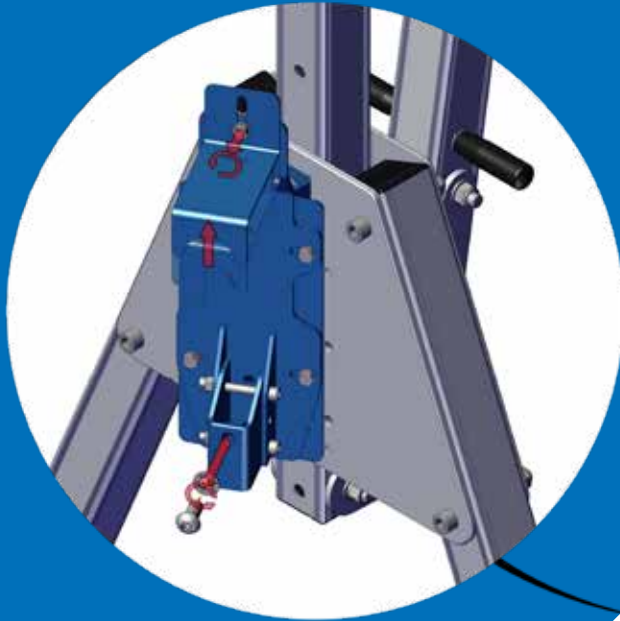

Appropriate PPE should be worn: ➤ Gloves ➤ Protective Footwear

Assembling the PORTAGANTRY Small and Medium: FABXR/Checkmate Bracket



- 1 The bracket comes with the bolts supplied, as shown above.



- 2 Before attaching the bracket to the device, disassemble the bracket.

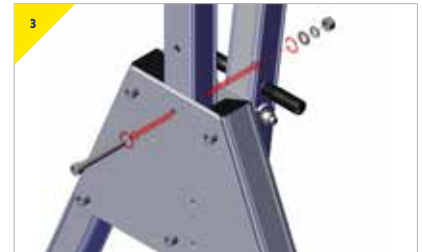

- 3 Remove the bottom bolt from the trap plate.



- 4 Present the bracket to the trap plate, insert and secure the M16 bolt supplied with the bracket.

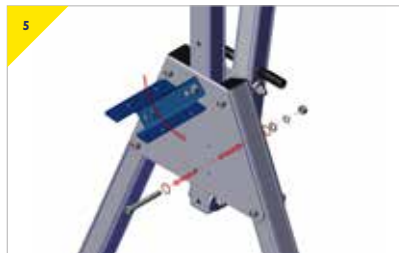

- 5 Remove the bottom bolt from the trap plate, and swing the bracket into position.

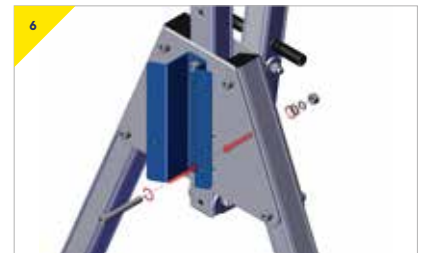

- 6 Insert the bottom M16 bolt supplied with bracket and secure.

> Assembly Instructions: PORTAGANTRY®; S & M



- > Re-assemble the bracket to the plate.



- > Prepare the bracket to receive the device, and remove the bolt from the bottom connector and loosen the top connector.

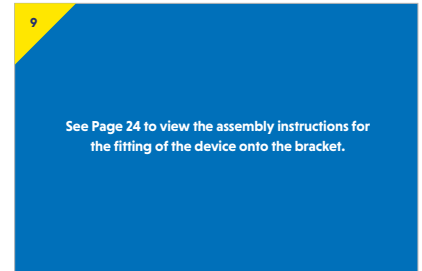

See Page 24 to view the assembly instructions for the fitting of the device onto the bracket.

➤ Assembly Instructions: PORTAGANTRY®

The following instructions detail the assembly of the FABXR/Checkmate Bracket [US-RAWB001000] for the Davits & Gantry Winch Column.



Appropriate PPE should be worn: ➤ Gloves ➤ Protective Footwear

Assembling the PORTAGANTRY Intermediate and above sizes: FABXR/Checkmate Bracket



- › The bracket comes with the pins supplied, as shown above.



- › Adjust the width of the wings to 3" (76.2mm) to fit on the winch column.



- › Present the bracket onto the winch column.

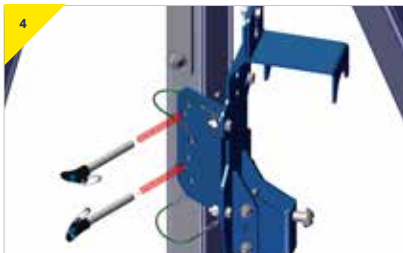

- › Insert pins provided to secure bracket to section.



- › Prepare the bracket to receive the device, making sure all the bolts for the bottom connector have been tightened. Remove the bolt from the bottom connector and loosen the top connector.



> Assembly Instructions: TDAVIT®

The following instructions detail the assembly of the FABXR/Checkmate Bracket [US-RAWB001000] for the Davits & Gantry Winch Column.

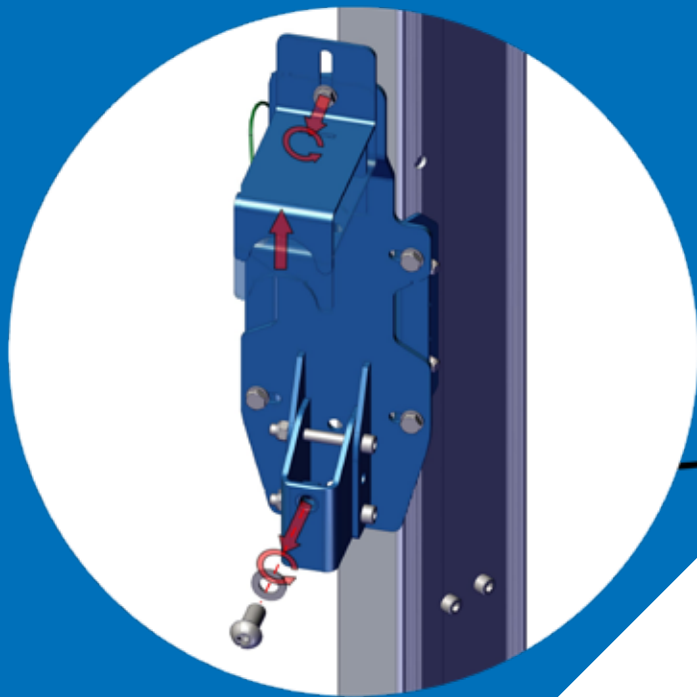

Appropriate PPE should be worn: > **Gloves** > **Protective Footwear**

Assembling the TDAVIT: FABXR/Checkmate Bracket



- The bracket comes with the pins supplied, as shown above.

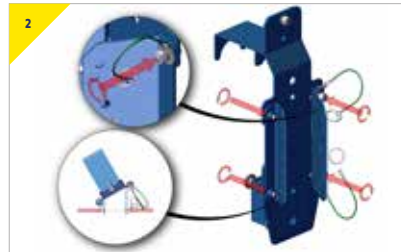

- Adjust the width of the wings to 3" (76.2mm) to fit on the TDAVIT column section.



- Present to the TDAVIT column.



- Insert the pins provided to secure bracket to the section.



- Prepare the bracket to receive the device and remove the bolt from the bottom connector and loosen the top connector.

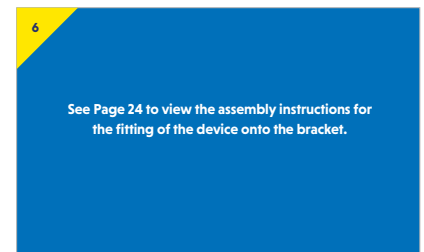

➤ Assembly Instructions: PORTADAVIT QUANTUM[®]

The following instructions detail the assembly of the FABXR/Checkmate Bracket [US-RAWB001000] for the Davits & Gantry Winch Column.

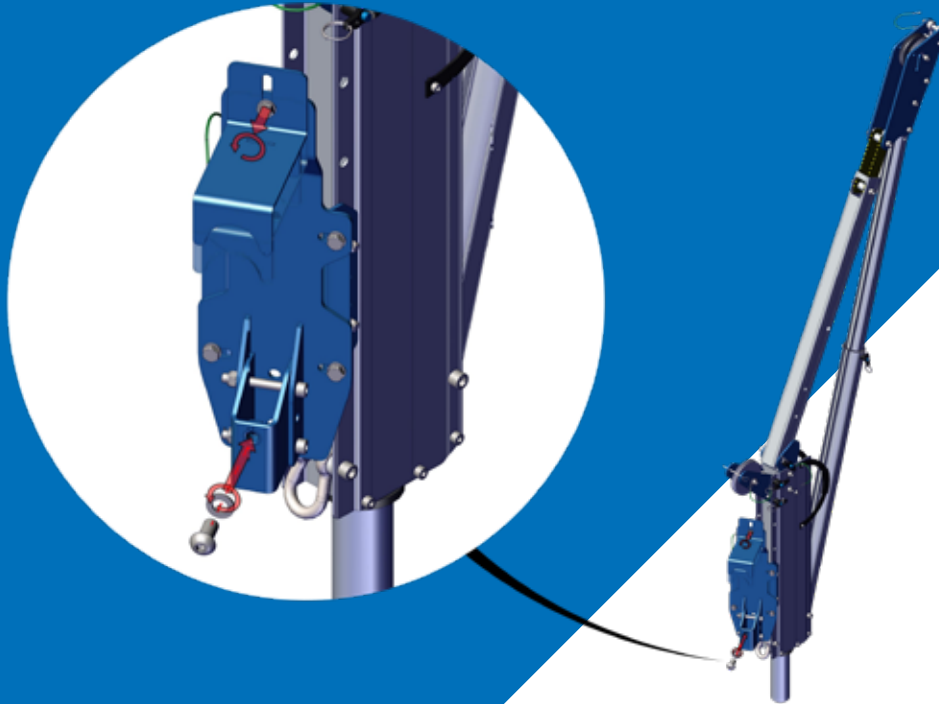

Appropriate PPE should be worn: ➤ **Gloves** ➤ **Protective Footwear**

For this configuration a sheave bracket column is required.
US-RAWB000095 – Sheave bracket PDQ column Medium sheave (4-7mm).

Assembling the PORTADAVIT QUANTUM: FABXR/Checkmate Bracket



- 1
- The bracket comes with the pins supplied, as shown above.

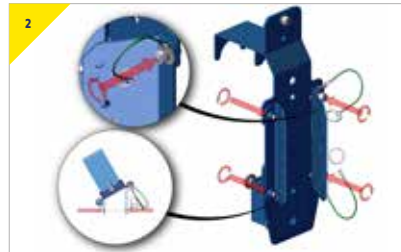

- 2
- Adjust the width of the wings to 3" (76.2mm) and fit the bracket onto the column.



- 3
- Present the bracket into the column.



- 4
- Insert the pins provided with the bracket.

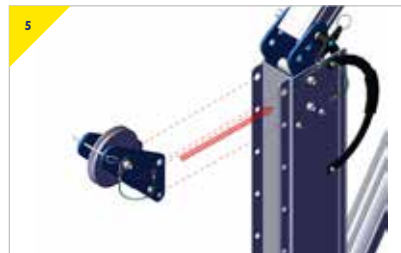

- 5
- Present the sheave bracket to the top of the column.



- 6
- Insert the pins provided.

➤ Assembly Instructions: PORTA DAVIT QUANTUM®



- Prepare the bracket to receive the device and remove the bolt from the bottom connector and loosen the top connector.

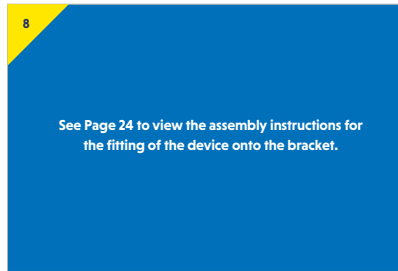

> Assembly Instructions: PORTADAVIT QUANTUM[®]

The following instructions detail the assembly of the FABXR/Checkmate Bracket [US-RAWB001000] for the Davits & Gantry Winch Column.

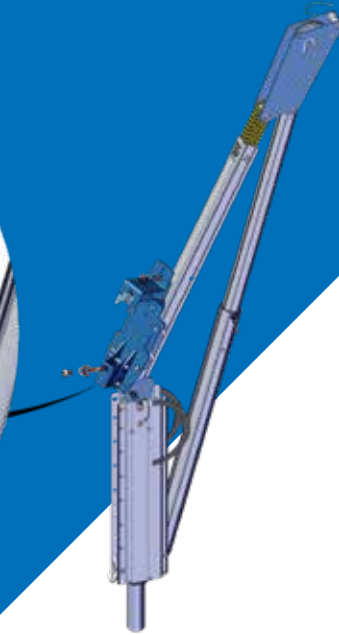
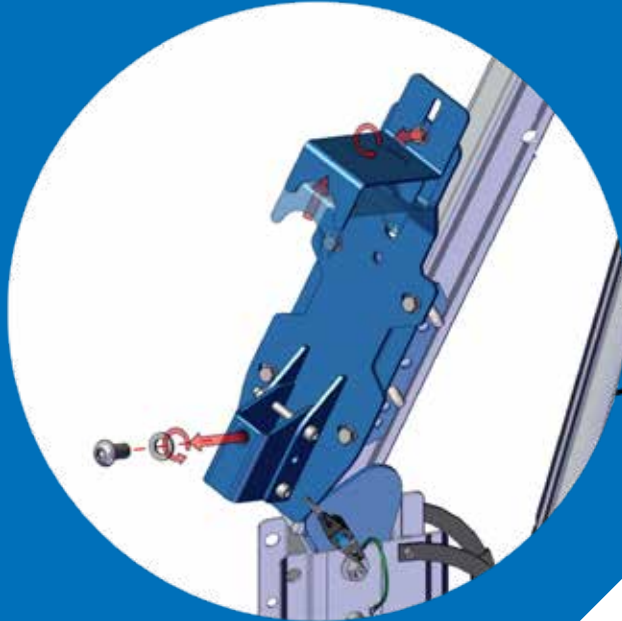

Appropriate PPE should be worn: > **Gloves** > **Protective Footwear**

Assembling the PORTADAVIT QUANTUM Backstay (Single Winch): FABXR/Checkmate Bracket



- The bracket comes with the pins supplied, as shown above.

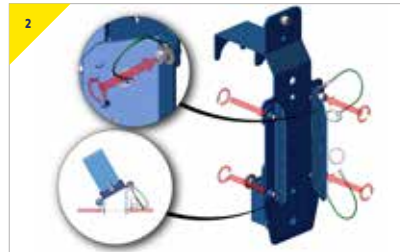

- Adjust the width of the wings to 2 1/2" (63.5mm) and fit the bracket onto the backstay.



- Present the bracket into the backstay.



- Insert the pins provided with the bracket.



- Prepare the bracket to receive device, remove the bolt from the bottom connector and loosen the top connector.

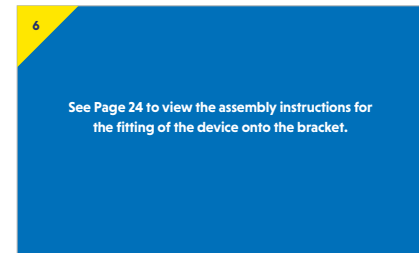

See Page 24 to view the assembly instructions for the fitting of the device onto the bracket.

➤ Assembly Instructions: PORTADAVIT QUANTUM®

The following instructions detail the assembly of the FABXR/Checkmate Bracket [US-RAWB001010] for the PORTADAVIT QUANTUM Backstay (Double Winch).

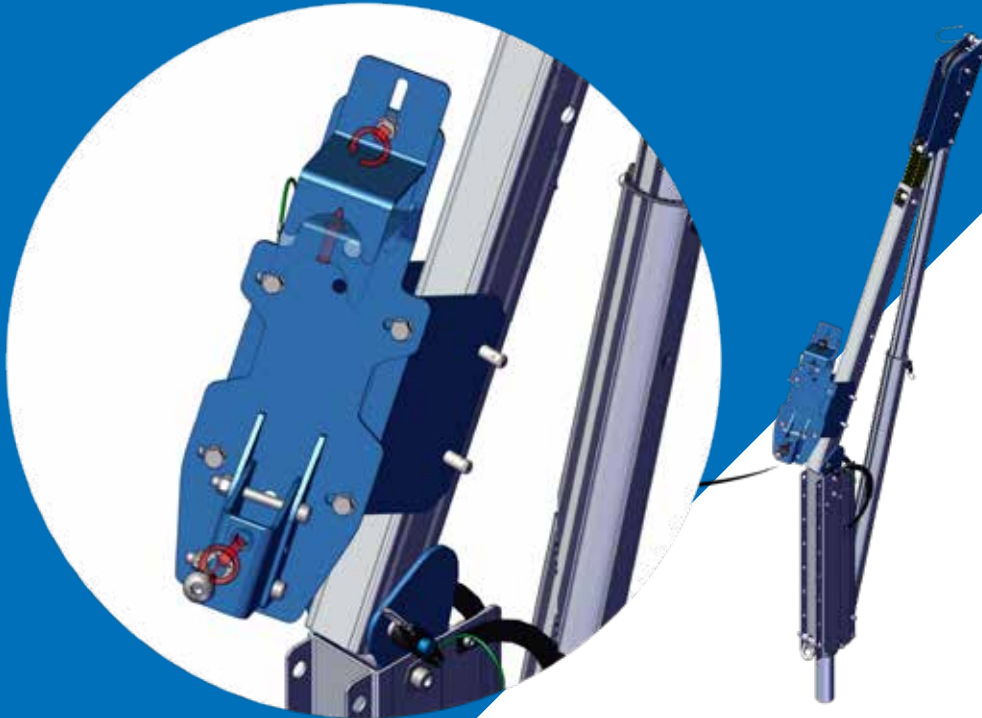

Appropriate PPE should be worn: ➤ Gloves ➤ Protective Footwear

Assembling the PORTADAVIT QUANTUM Backstay (Double Winch): FABXR/Checkmate Bracket



- The bracket comes with the pins supplied, as shown above.



- Adjust the width of the wings to 2 1/2" (76.2mm) and fit the bracket onto the backstay.



- Present the bracket into the backstay.



- Insert the pins provided with the bracket.



- Prepare the bracket to receive device, remove the bolt from the bottom connector and loosen the top connector.

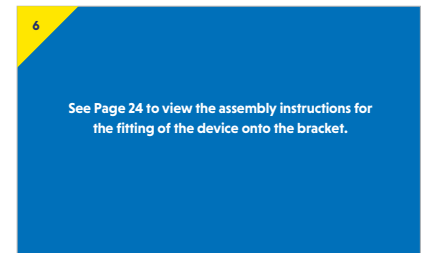

See Page 24 to view the assembly instructions for the fitting of the device onto the bracket.

➤ **Assembly Instructions:** Fitting the device

The following instructions detail the assembly of the device being attached into the FABXR/Checkmate bracket.



Appropriate PPE should be worn: ➤ **Gloves** ➤ **Protective Footwear**

Fitting the device into the FABXR/Checkmate Bracket



- Present the device onto the bracket.

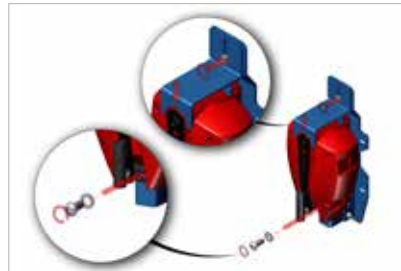

- Insert the bottom bolt to secure the device into position. Adjust the top connector in the suitable position and secure by tightening the bolt.



- The device is now ready to use.

Contact Us

REID Lifting Inc, USA

7900 International Drive,
Suite 300,
Bloomington,
MN 55425
USA

- > +1(888)-721-6411
- > info@reidlifting.com
- > us.reidlifting.com

All information herein is copyright protected by REID Lifting Ltd. All company and product names are Trade Mark and Trade Name protected and all REID Lifting Ltd. Product IPR is protected under Patents, Patents Pending and/or Design Rights.

 Printed using environment friendly processes and materials.